

# ECHO-PIEZO TRANSDUCER

B91 SERIES

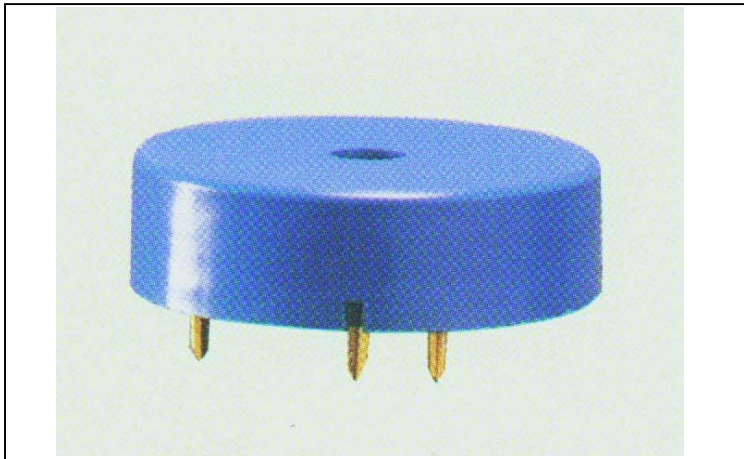

## FEATURES:

- Feed-back type
- Ultra small size and lightweight
- Low current consumption
- Extremely durable & long life
- Operating temperature  $-20^{\circ}\text{C}$ ~ $+70^{\circ}\text{C}$
- Storage temperature  $-30^{\circ}\text{C}$ ~ $+70^{\circ}\text{C}$

## TEST CIRCUIT

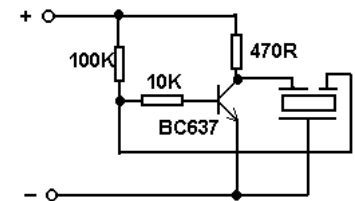

## DIMENSIONS: (unit: mm)

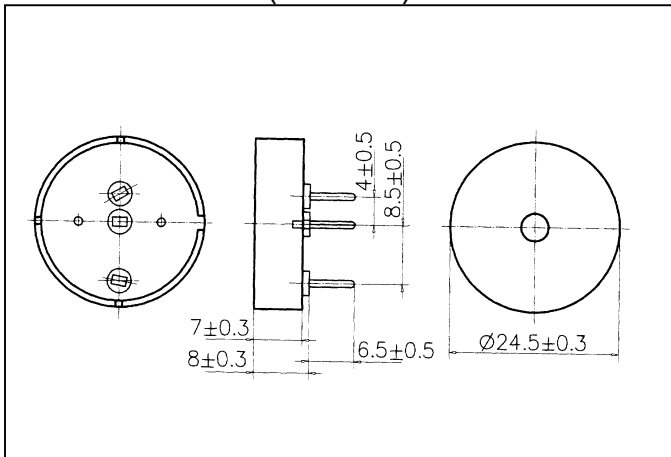

## FREQUENCY RESPONSE:

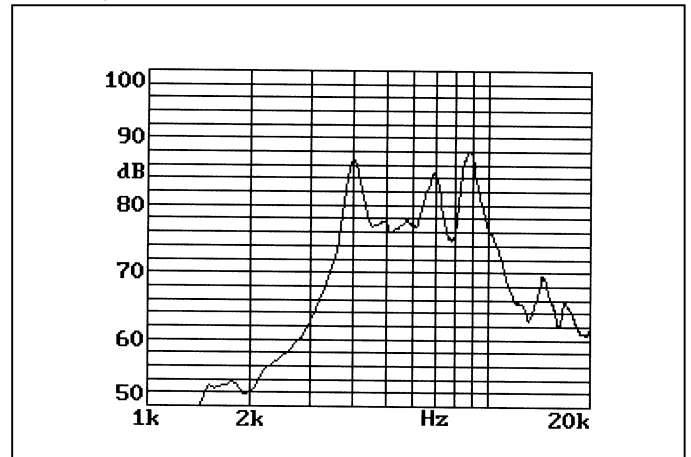

## SPECIFICATIONS:

Model Number	B91B03P
Sound Pressure Level	80dBA Min. at 10cm
Static Capacitance	18,000pF $\pm$ 30% at 120Hz
Resonant Frequency	3.5 $\pm$ 0.5KHz
Input Voltage	12VDC
Max. Input Voltage	20VDC
Current Consumption	20mA Max.
Operating Temperature	$-20^{\circ}\text{C}$ ~ $+110^{\circ}\text{C}$
Storage Temperature	$-30^{\circ}\text{C}$ ~ $+110^{\circ}\text{C}$
Weight	3g