

ECHO-PIEZO TRANSDUCER

B90 SERIES

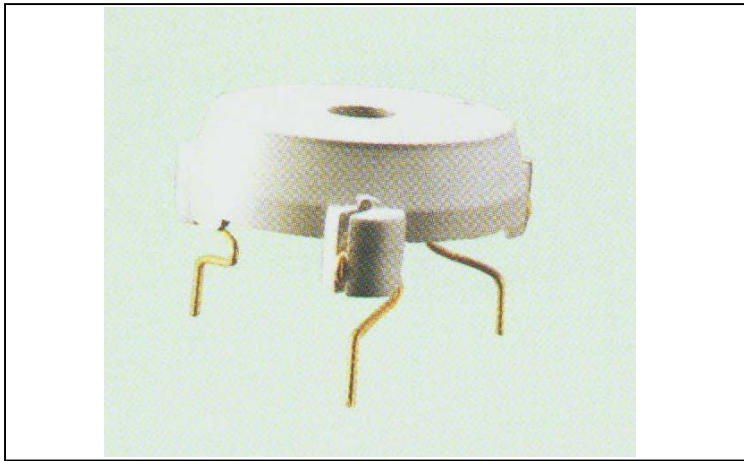

FEATURES:

- Feed-back type
- Ultra small size and lightweight
- Low current consumption
- Extremely durable & long life
- Operating temperature -20°C ~ $+70^{\circ}\text{C}$
- Storage temperature -30°C ~ $+70^{\circ}\text{C}$

TEST CIRCUIT

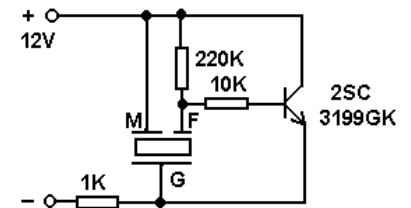

DIMENSIONS: (unit: mm)

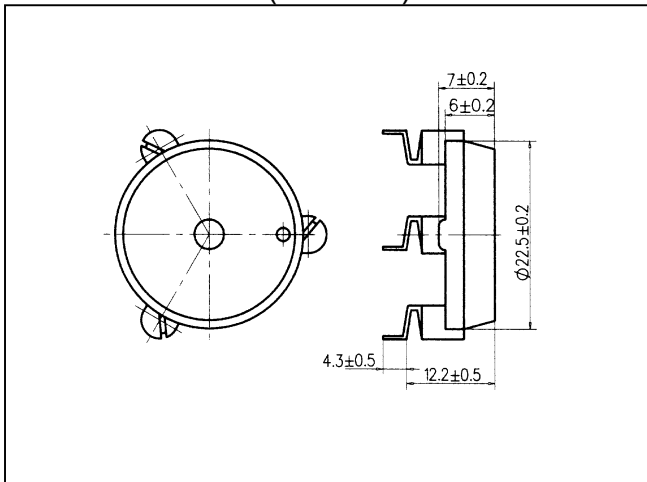

FREQUENCY RESPONSE:

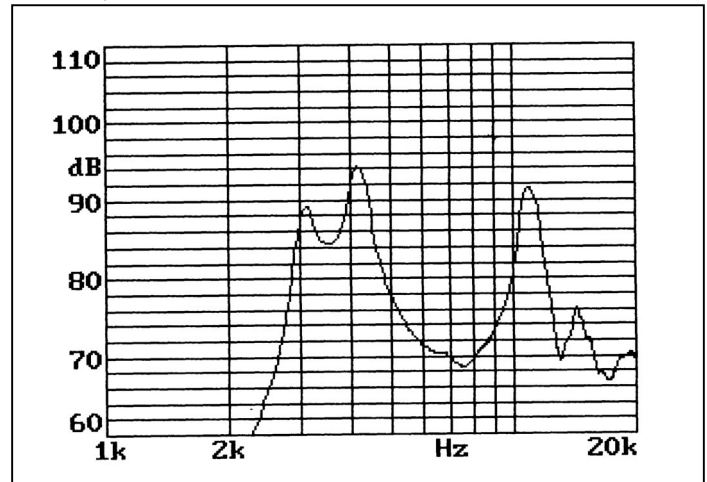

SPECIFICATIONS:

Model Number	B90B03P
Sound Pressure Level	90dBA Min. at 10cm
Static Capacitance	12,000pF \pm 30% at 120Hz
Resonant Frequency	3.6 \pm 0.5KHz
Input Voltage	12VDC
Max. Input Voltage	20VDC
Current Consumption	15mA Max.
Operating Temperature	-20°C ~ $+60^{\circ}\text{C}$
Storage Temperature	-30°C ~ $+70^{\circ}\text{C}$
Weight	3g